



World Headquarters  
601 Rayovac Drive  
Madison, WI 53711  
Telephone 1-800-331-4522  
Internet [www.rayovac.com](http://www.rayovac.com)

Marketing Data Sheet - Batteries

S6600145  
Issue D  
Memo No: [MDSR0104](#)

Rayovac Stock Number: **HD-C**

Name: **HD-C HEAVY DUTY INDUSTRIAL CARBON ZINC**

**ENGINEERING DATA:**

**Cell Chemistry:** Carbon Zinc

**Designation:** ANSI/NEDA – 14CD (C), IEC – R14

**Nominal Voltage:** 1.5 volts

**Approximate Weight:** 1.5 Oz (42.5 grams)

**Approximate Volume:** 1.6 CU IN (26.2 CU CM)

**Operating Temp. Range:** -30° C to 55° C (-20° F to 130° F)

**Terminals:** Flashlight

**Shell:** Steel

**Environmental:** Meets Environmental Protection Agency (EPA) Requirements For Landfill Disposal.  
No Mercury Added Formulation  
[Rayovac Material Safety Data Sheets](#)

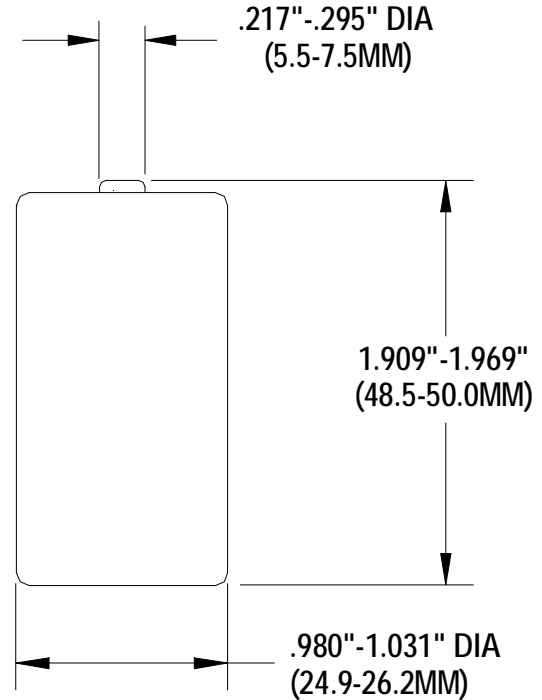

**TYPICAL INITIAL SERVICE AT 70°F (HOURS)  
CUTOFF VOLTAGE**

APPLICATION <u>DUTY CYCLE</u>	LOAD <u>(OHMS)</u>	CURRENT <u>(MA at 1.2V)</u>	<u>CUTOFF VOLTAGE</u>					mAh <u>CAPACITY To 0.9V</u>
			1.2V	1.1V	1.0V	0.9V	0.8V	
RADIO (4 HRS/DAY)	20	60	29	36	41	45	-	2,800
CASSETTE (1 HR/DAY)	6.8	176	5.9	8.7	11.0	13.6	-	2,350
FLASHLIGHT (4 MIN/HR-8 HR/DAY)	3.9	308	2.4	4.4	6.0	7.3	-	2,150
TOY/GAME (1 HR/DAY)	3.9	308	1.6	3.5	5.0	6.3	7.5	1,900
FLASHLIGHT (CONTINUOUS)	3.9	308	1.3	2.4	3.3	4.0	-	1,150
FLASHLIGHT (4 MIN/15 MIN-8 HR/DAY)	2.2	545	0.2	0.8	1.6	2.6	-	1,225

538392

This data is subject to change. Performance information is typical. Contents herein do not constitute a warranty.